

F780HD, 3", 3-Way Butterfly Valve

Resilient Seat, 304 Stainless Steel Disc



Technical Data	
Service	chilled, hot water, up to 60% glycol
Flow Characteristic	modified linear
Controllable Flow Range	90° rotation
Valve Size	3 " [80]
End Fitting	for use with ANSI class 125/150 flanges
Body	ductile iron ASTM A536
Body Finish	epoxy powder coated
Seat	EPDM standard
Shaft	416 stainless steel
Bushings	RPTFE
Disc	304 stainless steel
Body Pressure Rating	200 psi at -20°F to +150°F
ANSI Class	125
Number of Bolt Holes	4
Lug Threads	5/8-11 UNC
Media Temperature Range (Water)	-22°F to 250°F [-30°C to 120°C]
Close-Off Pressure	200 psi
Rangeability	10:1 (for 30° to 70° range)
Maximum Velocity	12 FPS
Cv	302
Weight	50.5 lb [22.9 kg]
Leakage	0%
Servicing	maintenance free

Application

Valve is designed for use in ANSI flanged piping systems to meet the needs of bi-directional high flow HVAC hydronic applications with 0% leakage. Typical applications include cooling tower bypass, primary flow change-over systems, and large air handler coil control. Valve face-to-face dimensions comply with API 609 & MSS-SP-67, Completely assembled and tested, Ready for installation.

Jobsite Note

Valve assembly should be stored in a weather protected area prior to installation. Reference the butterfly valve installation instruction for additional information.

Flow/Cv								
Cv 10°	Cv 20°	Cv 30°	Cv 40°	Cv 50°	Cv 60°	Cv 70°	Cv 80°	Cv 90°
0.2	9	18	39	70	116	183	275	302

Suitable Actuators

	Non-Spring	Electronic Fail-Safe
F780HD	2*GMB(X)	2*GKB(X)

Dimensions (Inches [mm])

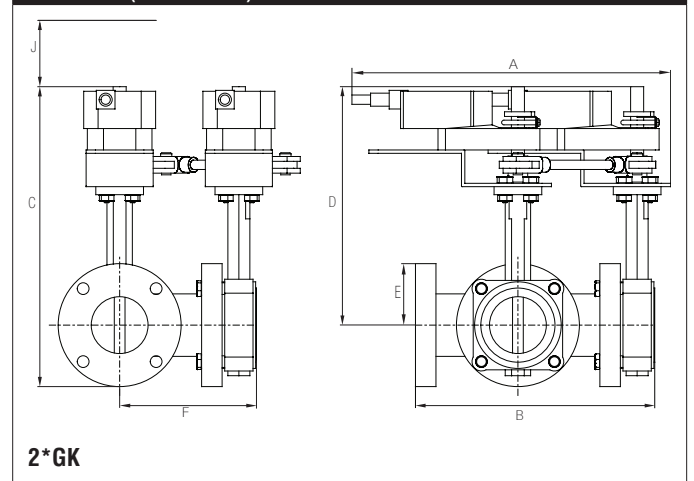

A	B	C	D	E	F	J
18.98"	12.87"	16.1"	12.73"	5.50"	7.38"	3.9" [100]
[482]	[326.9]	[375]	[323]	[140]	[187]	

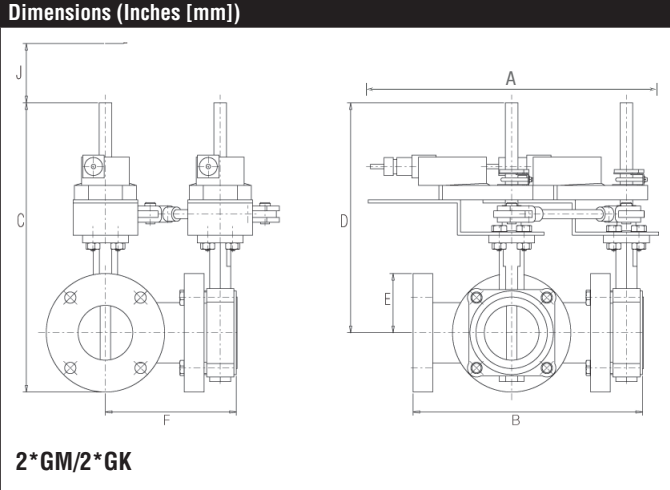

A	B	C	D	E	F	J
18.98" [482]	12.87" [326.9]	16.1" [375]	12.73" [323]	5.50" [140]	7.38" [187]	3.9" [100]

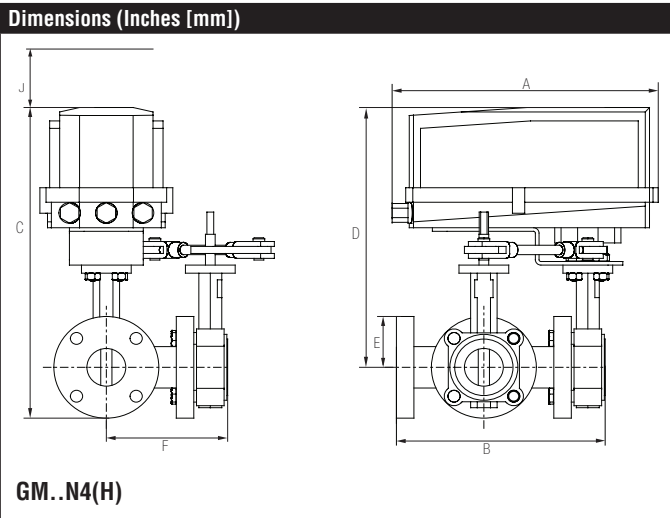

A	B	C	D	E	F	J
18.98" [482]	12.87" [326.9]	20.6" [523.2]	17.25" [438]	3.34" [85]	7.38" [187]	7.8" [198]

2*GMX24-MFT-X1

Modulating, Non-Spring Return, 24 V, Multi-Function Technology®

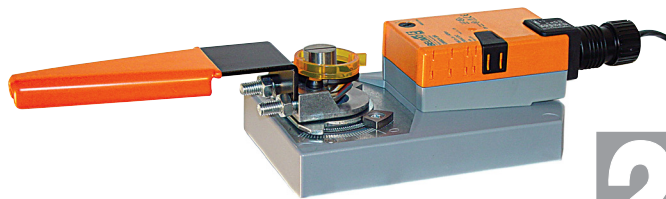

Technical Data	
Power Supply	24 VAC, ±20%, 50/60 Hz, 24 VDC, ±10%
Power consumption in operation	15 W
Power consumption in rest position	4 W
Transformer sizing	14 VA (class 2 power source)
Electrical Connection	3ft [1m], 10ft [3m] or 16ft [5m] 18 GA appliance cables, with 1/2" conduit connector
Overload Protection	electronic throughout 0° to 95° rotation
Operating Range	DC 2...10 V (default), 4 to 20 mA w/ ZG-R01 (500 Ω, 1/4 W resistor), variable (VDC, floating point, on/off)
Operating range Y variable	starting point DC 0.5...30 V end point DC 2.5...32 V
Input Impedance	100 kΩ for 2 to 10 VDC (0.1 mA), 500 Ω for 4 to 20 mA, 1500 Ω for PWM, floating point and On/Off
Position Feedback	DC 2...10 V, Max. 0.5 mA, VDC variable
Angle of rotation	Max. 95°, adjustable with mechanical stop
direction of rotation motor	reversible with built-in switch
Position indication	reflective visual indicator (snap on)
Manual override	external push button
Running time motor	150 sec, constant, independent of load
Ambient humidity	5 to 95% RH non condensing (EN 60730-1)
Ambient temperature	-22...122 °F [-30...50 °C]
Non-operating temperature	-40...176 °F [-40...80 °C]
Degree of Protection	IP54, NEMA 2
Agency Listing	cULus acc. to UL60730-1A/-2-14, CAN/CSA E60730-1:02, CE acc. to 2004/108/EC and 2006/95/EC
Noise level, motor	<45 dB (A)
Maintenance	maintenance free
Quality Standard	ISO 9001
Weight	9.9 lb [4.5 kg]

†Rated Impulse Voltage 800V, Type action 1, Control Pollution Degree 3.

Wiring Diagrams
INSTALLATION NOTES

- Actuators with appliance cables are numbered.
- Provide overload protection and disconnect as required.
- Actuators may also be powered by 24 VDC.
- Only connect common to negative (-) leg of control circuits.
- A 500 Ω resistor (ZG-R01) converts the 4 to 20 mA control signal to 2 to 10 VDC.
- Control signal may be pulsed from either the Hot (Source) or Common (Sink) 24 VAC line.
- For triac sink the Common connection from the actuator must be connected to the Hot connection of the controller. Position feedback cannot be used with a triac sink controller; the actuator internal common reference is not compatible.
- Actuators may be controlled in parallel. Current draw and input impedance must be observed.
- Master-Slave wiring required for piggy-back applications. Feedback from Master to control input(s) of Slave(s).
- Meets cULus requirements without the need of an electrical ground connection.

WARNING! LIVE ELECTRICAL COMPONENTS!
 During installation, testing, servicing and troubleshooting of this product, it may be necessary to work with live electrical components. Have a qualified licensed electrician or other individual who has been properly trained in handling live electrical components perform these tasks. Failure to follow all electrical safety precautions when exposed to live electrical components could result in death or serious injury.

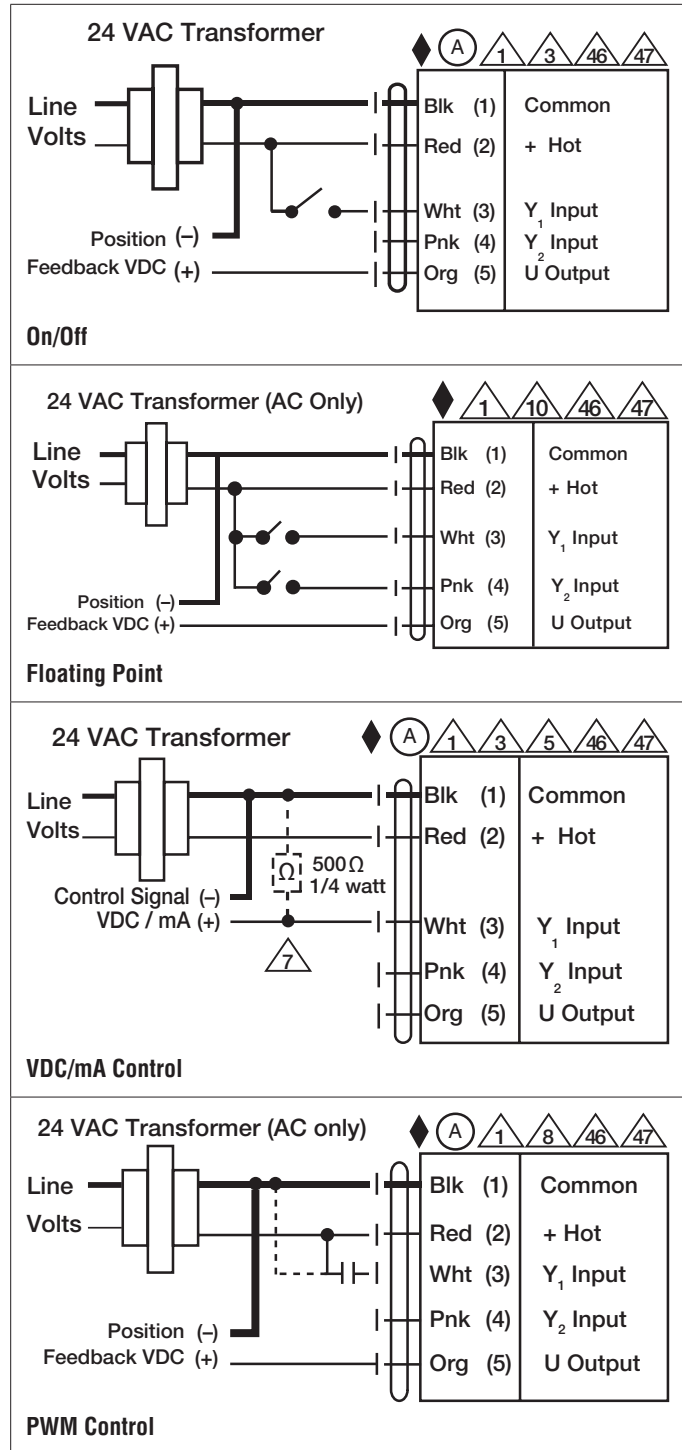

2*GMX24-MFT-X1

Modulating, Non-Spring Return, 24 V, Multi-Function Technology®

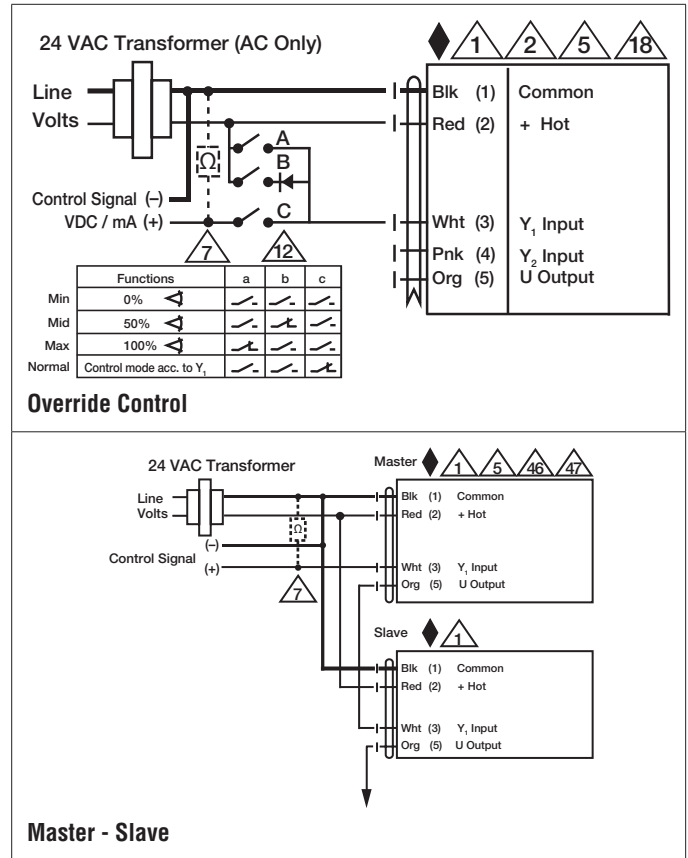

Date created, 12/18/2018 - Subject to change. © Belimo Aircontrols (USA), Inc.